

**OUTLINE OF FORMING**

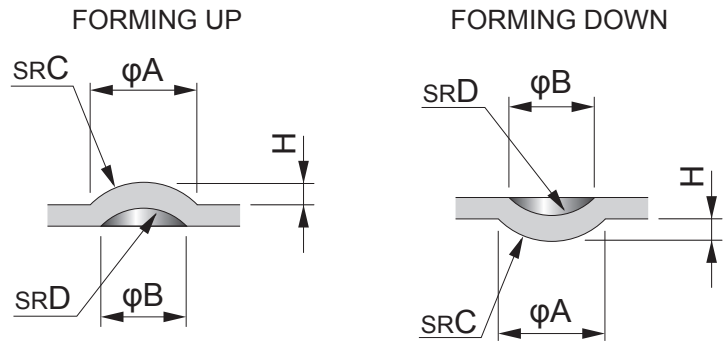

Forming process of embossed material such as dimples.  
 Used for positioning or decorative pattern of the material.

**TOOLING STRUCTURE (NC 1-1/4)**

**NOTE**

FORMING UP

FORMING DOWN

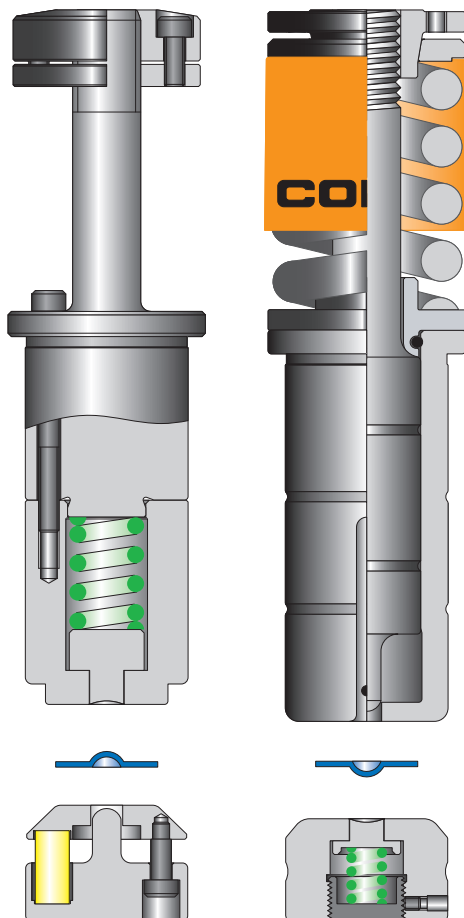

- 1) The height(H) is preferably less than 40% of the diameter(A).
- 2) The height(H) is preferably less than three times of the material thickness.
- 3) It would be  $D \geq H$ .
- 4) Please indicate the dimension of either A, B, C, D, when you order.

For More information,  
 please contact  
 CONIC tool sales desk.

**CONIC Co., Ltd.**  
 10-5 Taiheidai, Shoo-cho, Katsuta-gun,  
 Okayama 709-4321 Japan  
 Email: tools@conic.co.jp  
<https://www.conic.co.jp>

**CONIC PRECISION Co., Ltd.**  
 55/22 Moo 4, Buengkumphroy, Lumlukka,  
 Phatumthani 12150 Thailand  
 TEL: (662) 159-9870 FAX: (662) 159-9872  
 Email: conic\_thai@conic.co.jp