

PARTS NAME OF STANDARD TOOLING

Turret punch press Tool is composed of several parts. Also, the style of the tool varies depending on the machine to be used. This time, we summarized the part name and functions.

THICK TURRET TOOLING

The thick turret tooling receives the pressing force of the **press striker** with the **head**, transmits the force to the **punch body**, and punches the workpiece with the **punch edge** and the **die**. Also, after processing, the workpiece is held by the **guide and stripper** by the force of the **spring**, and the punch edge is pulled out.

EACH PART NAME AND FUNCTION OF TOOL

1. PUNCH BODY, DIE

It punched out workpiece at punch and die.

2. STRIPPER

A part that holds the workpiece during processing. After processing, the punch edge is pulled out from the workpiece at this part. (This is called a strip.)

3. GUIDE

Insert this part into the turret and hold and guide the punch body.

4. HEAD

Part that receives the force of the striker directly and conveys it to the driver and the punch body. In case of the small diameter tool, rotate it to adjust the punch length.

5. SPRING

Hold the workpiece during processing and pull the punch edge away from the work after processing. Use coil spring, urethane spring, disc spring and so on.

6. DRIVER

The part to attach the punch body. Also, add a shim between the driver and the punch and adjust the punch length. In the case of Protech III, adjustment is possible without shims.

7. RETAINER

Guide would be attached in this part. It also serves to hold the spring.

8. SPRING CANISTER

A combination of head, spring and retainer collar. It is possible to adjust the length of the tool without tools.

TOOLING STRUCTURE (Ex. LONG TYPE)

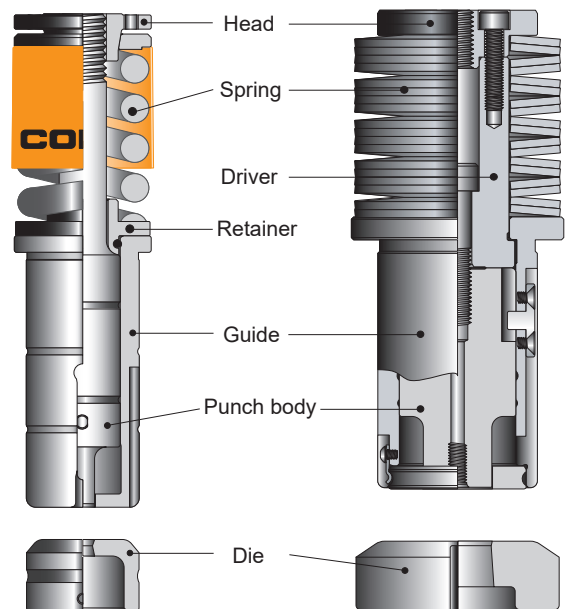

TOOLING STRUCTURE (EX. PROTECH 3)

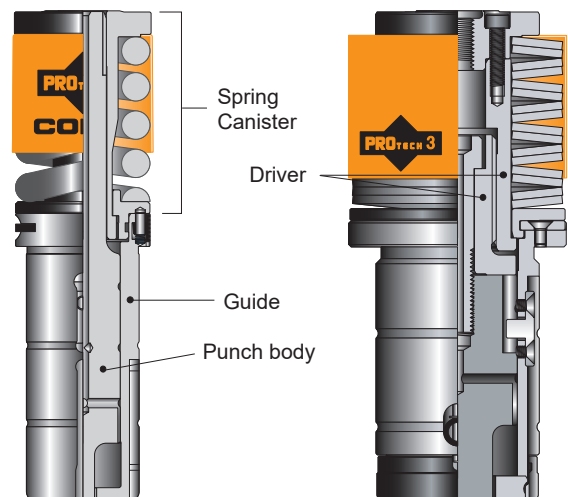

PARTS NAME OF STANDARD TOOLING

MURATA TYPE TOOLING

The Murata type toolings transmits the pressing force of the **press ram** to the mechanically **connected holder / punch body** and punches out the workpiece with the punch edge and the die. Also, after processing, the ram will forcibly pull up the holder.

Two types of Holders are as follows.

1. **114 Type** (Urethane stripper type)•••Low cost and simple structure.
2. **Vulcan Type** (Metal stripper type)•••Designed for Strengthened stripping power compared to standard 114 Type.

EACH PART NAME AND FUNCTION OF TOOL

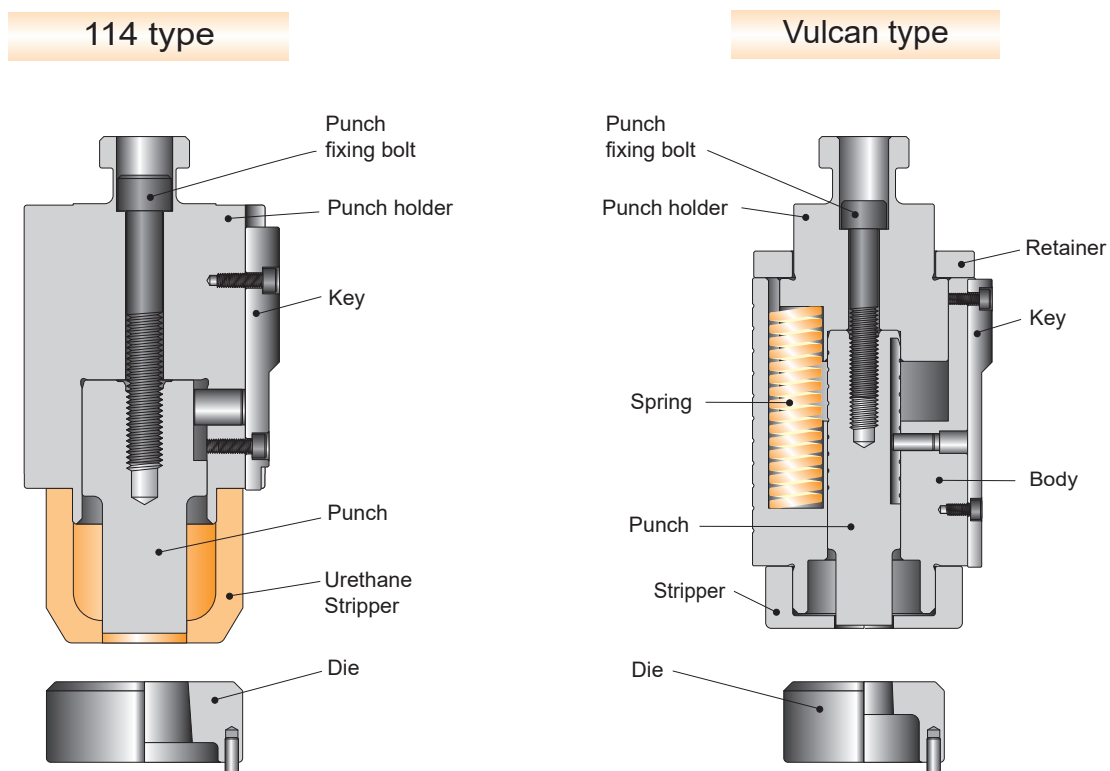

1.PUNCH HOLDER

Hold the punch body. Top of Holder would be connected directly to Press Ram.

2.BODY

It is inserted into the turret and serves as a guide for the punch holder.

3.KEY

Position the turret and the holder. It also serves to hold the tool in place when attached to the turret.

For other parts, please refer to “the thick turret tooling”

For More information,
please contact
CONIC tool sales desk.

CONIC Co., Ltd.

10-5 Taiheidai, Shoo-cho, Katsuta-gun,
Okayama 709-4321 Japan
Email: tools@conic.co.jp
<https://www.conic.co.jp>

CONIC PRECISION Co., Ltd.

55/22 Moo 4, Buengkumphroy, Lumlukka,
Phatumthani 12150 Thailand
TEL: (662) 159-9870 FAX: (662) 159-9872
Email: conic_thai@conic.co.jp