

TECHNICAL COUNSELING FAQ

Here are some of the questions we have contacted the Tool Consultation.

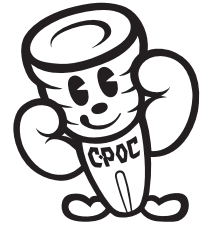

MATERIAL WARPING PREVENTION DURING PUNCHING

Q If a large number of punches are processed, the workpiece will warp and can no longer be processed. Are there any measures?

A When a large number of holes are punched using a turret punch press, the material (workpiece) may warp, and making it impossible to process or not be a product. (See Fig.1)

Fig.1 The sheet metal distorted after punching

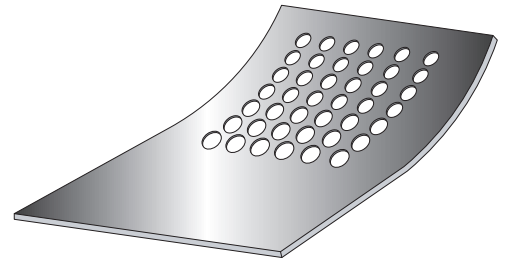

This is because when the punch out the workpiece, bending stress is generated at the same time as the shearing force, and internal stress is generated due to the plate pressing pressure of the tool.

After that, when the material is released from the plate press, the board warps due to the stress inside the material. (See Fig.2)

As a countermeasure...

1. A tapering process is applied to the material pressing surfaces of the guide or the stripper and the die to apply a stress in the direction opposite to the warpage to flatten the work. (see Fig.3)

Usually, a taper of 1 degree to 2 degree is added to one side or all around so that the die side is convex and the guide or the stripper side is concave.

Fig. 2 Punching force and stress

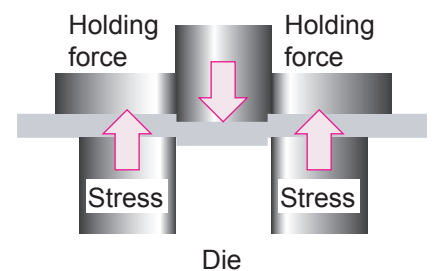
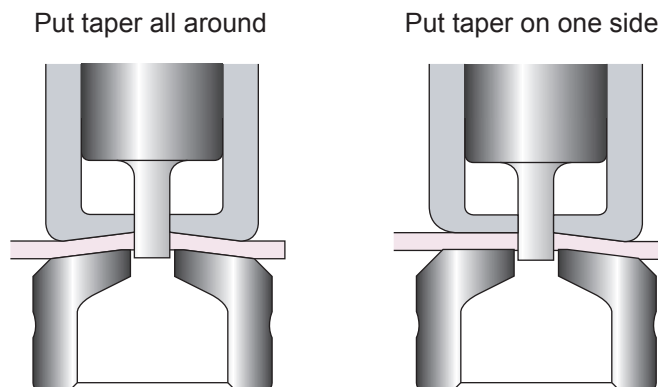

Fig.3 Put taper on a stripper and die



TECHNICAL COUNSELING FAQ

2. By strengthening the "plate holding force" to hold the material, the bending stress generated on the material is suppressed to reduce the warpage.

As a way to increase the plate holding force,

- a) Increase the force of the upper spring by raising the station.
- b) There is a way to increase the surface pressure around the punch by reducing the holding area of either or both of the guide or die. (see Fig.4)

Fig.4 Increase holding force

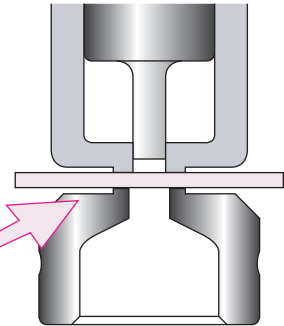

Tool with a slight relief on the guide / die so that only the area around the punch is pressed firmly.

3. Keep the edge of the punch and die sharp at all times.
Wear on the cutting edge increases shear resistance and causes warpage.
Please regrinding the cutting edge early and keep the cutting edge sharp at all times.
4. Punching with proper clearance.
An excessively large clearance increases the bending stress of the punching process.
Warpage can be reduced by proper clearance or slightly smaller clearance.
5. Use cluster tool.
In case of punching process with many same dimensions, warpage will be less if multiple holes are formed at one process with cluster tool than single punching. (See Fig.5)

Fig.5 Cluster tooling

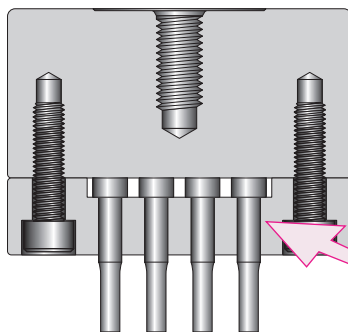

A cluster tooling that processes multiple holes at the same time.
A replaceable blade type is recommended.

For More information,
please contact
CONIC tool sales desk.

CONIC Co., Ltd.

10-5 Taiheidai, Shoo-cho, Katsuta-gun,
Okayama 709-4321 Japan
Email: tools@conic.co.jp
https://www.conic.co.jp

CONIC PRECISION Co., Ltd.

55/22 Moo 4, Buengkumphroy, Lumlukka,
Phatumthani 12150 Thailand
TEL: (662) 159-9870 FAX: (662) 159-9872
Email: conic_thai@conic.co.jp