

# MURATA WIEDMANN TYPE 114 STYLE



ISO9001  
JQA-2633



**CONIC**

**MURATA TYPE TOOLING**

**Punch Press Tools Standard Specifications And Options**

**STANDARD SHAPES**



RO



SQ



RE



OB



SD



WD

**PUNCHES·DIES STANDARD KEY POSITION SETTINGS (TOP VIEW)**

	114		VALCAN
	B·C	D~J	B~J
<b>PUNCHES</b>			
<b>DIES</b>			

**OPTIONAL KEY POSITION**

Please specify die key pin position.

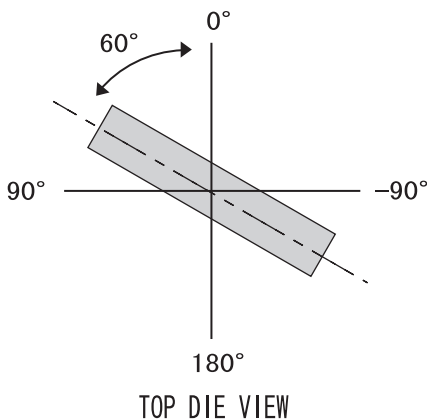

**Punch Shear Angles**

	ROOF TOP	RADIUS SHEAR	2-WAY CONCAVE
A	Add 1,500	Add 3,000	Add 3,000
B	Add 2,000		
C	Add 2,500	Add 4,000	Add 4,000
D·E·F	FREE OF CHARGE	FREE OF CHARGE	Add 5,000
G·H·J			Add 6,000

(UNIT JPY)

**URETHANE KICKERS**

Purpose of this unit is push down slug from the die.

Minimum size of the tool which we can put this unit is as followings.

- \* Shaped Tools - over width 6mm
- \* Round Tools - over  $\phi 4$
- \* Special Shapes and Width 4mm to 6mm - Please contact us.



# MURATA WIEDMANN TYPE 1 1 4 STYLE

## STANDARD SHAPES

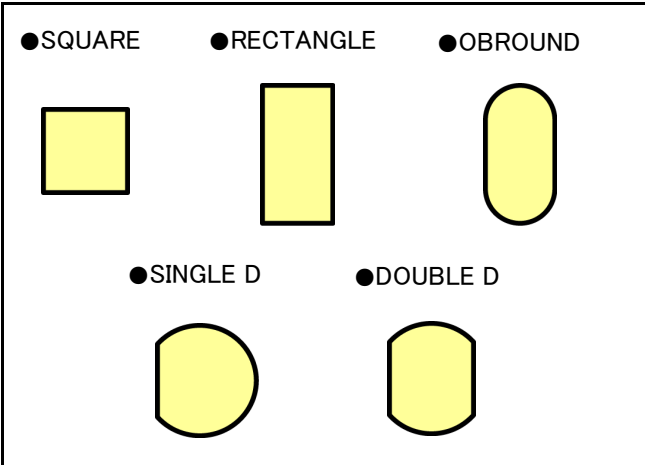

## SHAPES WITH RADIUS CORNERS

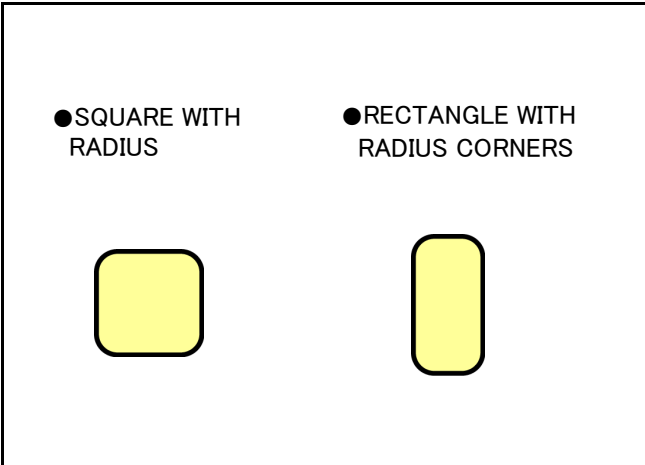

## SPECIAL SHAPES (CLASS 1)

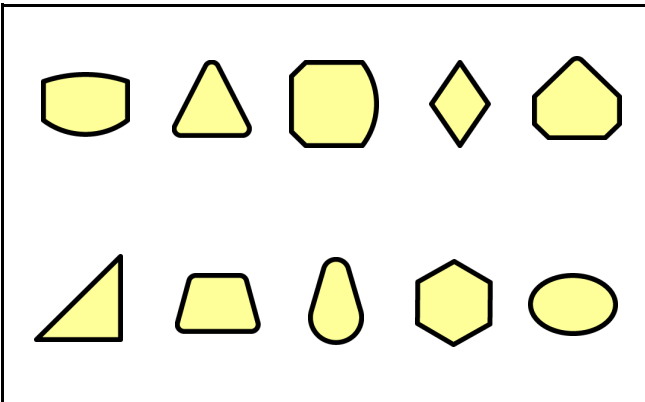

## SPECIAL SHAPES (CLASS 2)

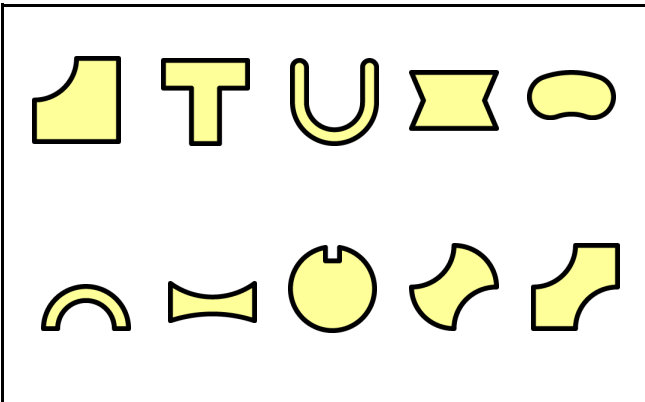

## SPECIAL SHAPES (CLASS 3)

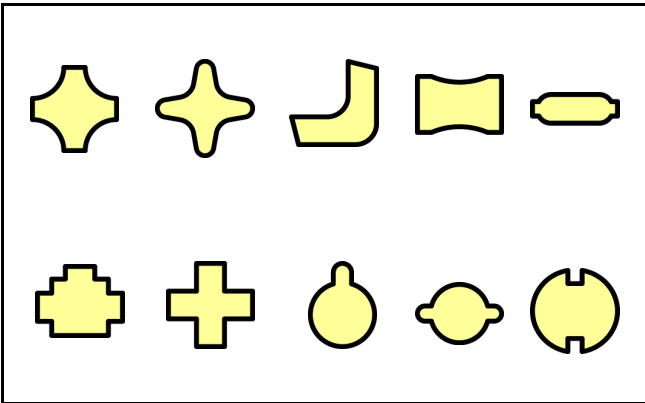

## SPECIAL SHAPES (CLASS 4)

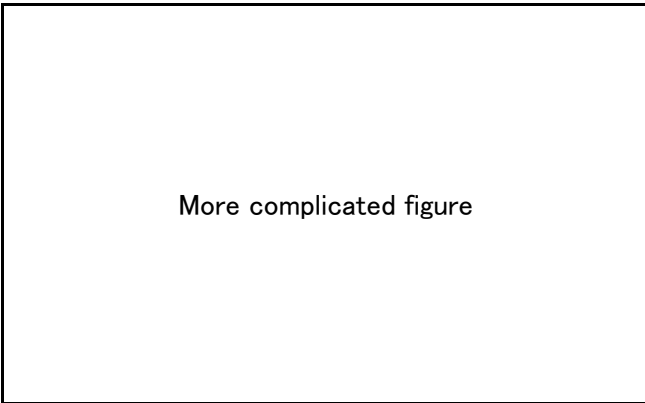

# MURATA WIEDMANN TYPE 114 STYLE

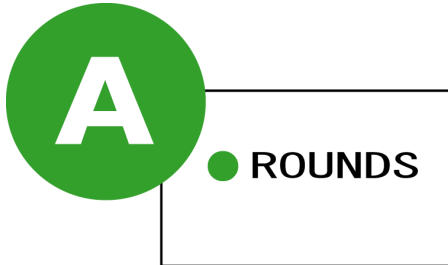

PUNCH

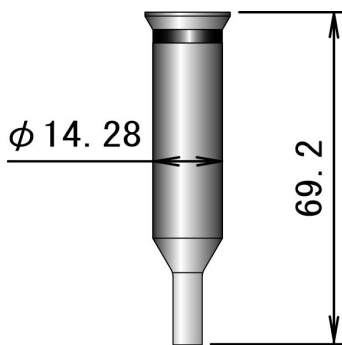

DIE

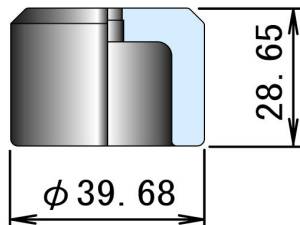

PUNCH

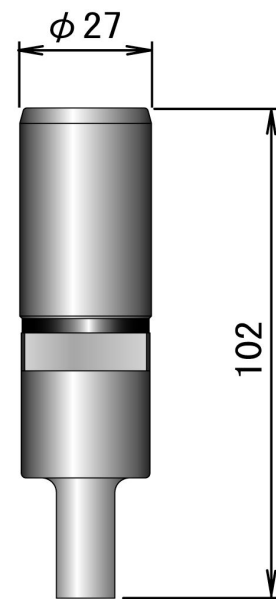

DIE

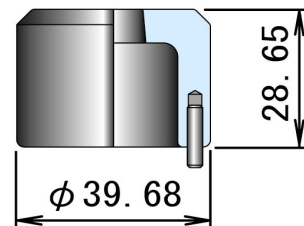

# MURATA WIEDMANN TYPE 1 1 4 STYLE



- ROUNDS
- STANDARD SHAPES
- SPECIAL SHAPES

PUNCH

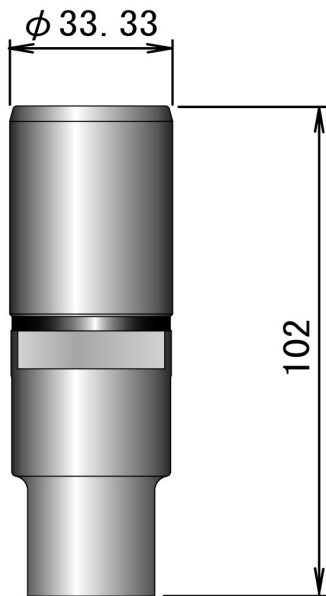

DIE

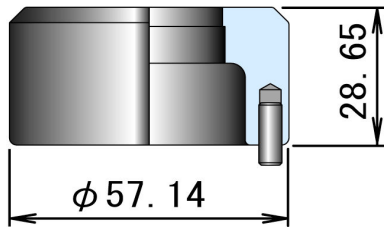

- ROUNDS
- STANDARD SHAPES
- SPECIAL SHAPES

PUNCH

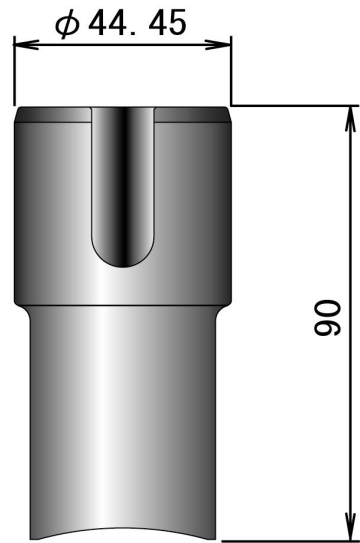

DIE

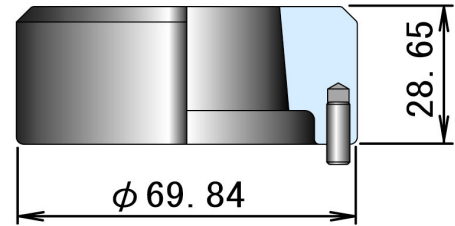

# MURATA WIEDMANN TYPE 1 1 4 STYLE

**E**

- ROUNDS
- STANDARD SHAPES
- SPECIAL SHAPES

**F**

- ROUNDS
- STANDARD SHAPES
- SPECIAL SHAPES

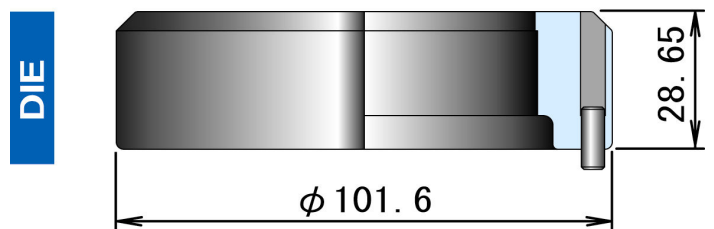
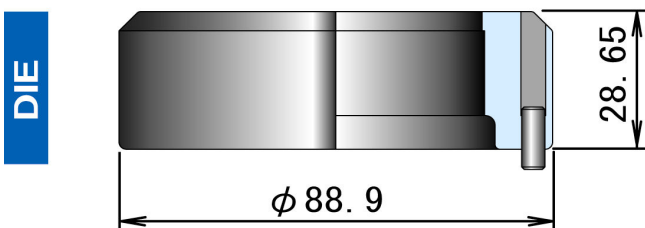
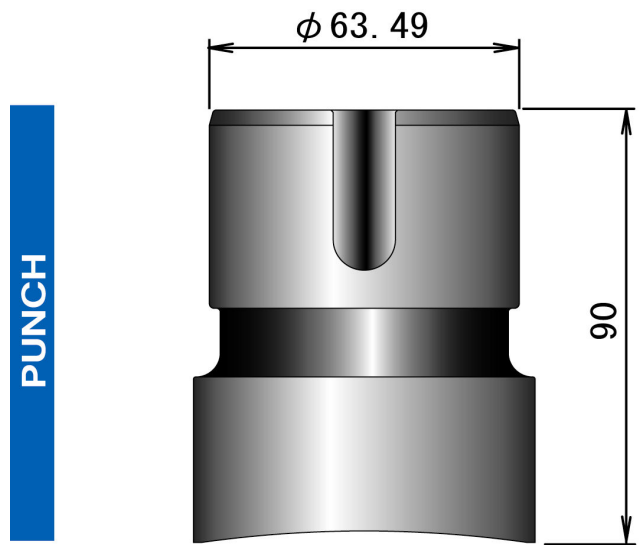
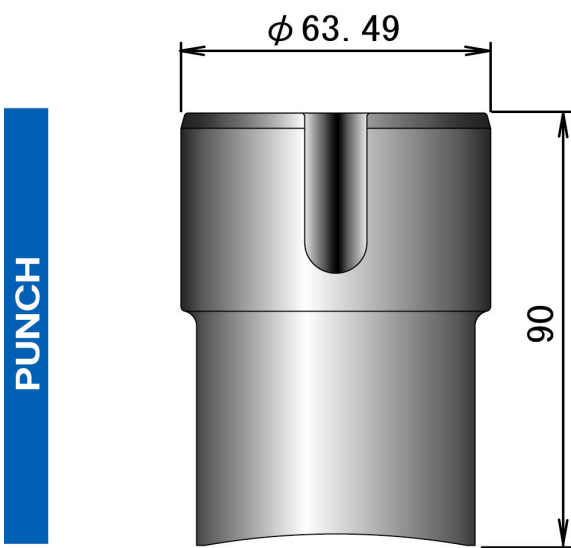

# MURATA WIEDMANN TYPE 1 1 4 STYLE



- ROUNDS
- STANDARD SHAPES
- SPECIAL SHAPES



- ROUNDS
- STANDARD SHAPES
- SPECIAL SHAPES

PUNCH

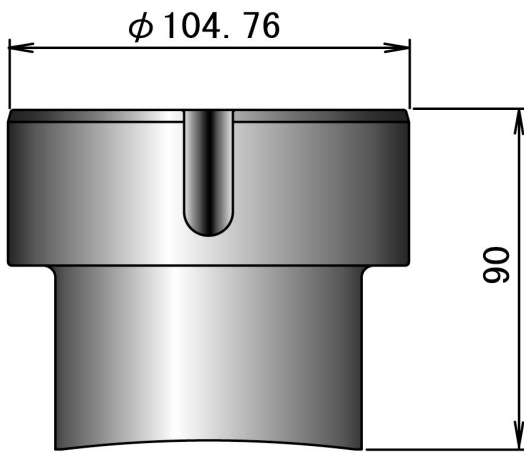

PUNCH

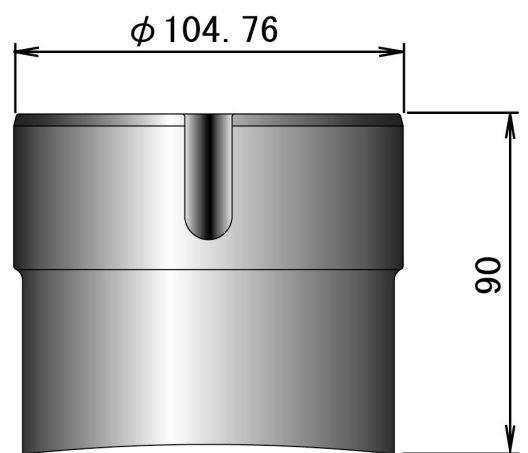

DIE

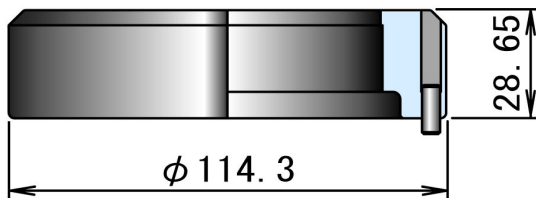

DIE

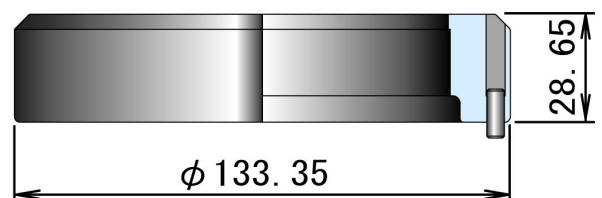

# MURATA WIEDMANN TYPE 1 1 4 STYLE

**J**

- ROUNDS
- STANDARD SHAPES
- SPECIAL SHAPES

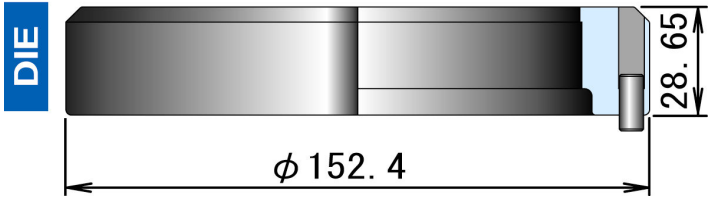
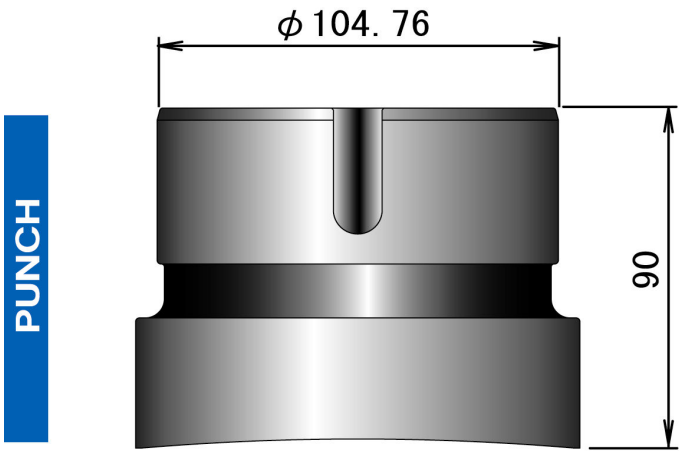

**CONIC**